

Investigating Sensory Extensions as Input for Interactive Simulations

Chris Hill*

Christian.N.Hill@colorado.edu
University of Colorado, Boulder
Boulder, Colorado, USA

Brett L. Fiedler

Brett.Fiedler@colorado.edu
University of Colorado, Boulder
Boulder, CO, USA

Casey Lee Hunt*

Casey.Hunt@colorado.edu
University of Colorado, Boulder
Boulder, CO, USA

Emily B. Moore

Emily.Moore@colorado.edu
University of Colorado, Boulder
Boulder, CO, USA

Sammie Crowder

Sammie.Crowder@colorado.edu
University of Colorado, Boulder
Boulder, CO, USA

Ann Eisenberg

Ann.Eisenberg@colorado.edu
University of Colorado, Boulder
Boulder, CO, USA



Figure 1: Participant uses weight sensory extensions to control *Ratio and Proportion* simulation

ABSTRACT

Sensory extensions enhance our awareness by transforming variations in stimuli normally undetectable by human senses into perceivable outputs. Similarly, interactive simulations for learning promote an understanding of abstract phenomena. Combining sensory extension devices with interactive simulations gives users the novel opportunity to connect their sensory experiences in the physical world to computer-simulated concepts. We explore this opportunity by designing a suite of wearable sensory extension devices that interface with a uniquely inclusive PhET Simulation, *Ratio and Proportion*. In this simulation, two hands can be moved on-screen to various values, representing different mathematical

ratios. Users explore changing hand heights to find and maintain ratios through visual and auditory feedback. Our sensory extension devices translate force, distance, sound frequency, and magnetic field strength to quantitative values in order to control individual hands in the computer simulation. This paper describes the design of the devices and our analysis of feedback from 23 high-school aged youth who used our designs to interact with the *Ratio and Proportion* simulation.

CCS CONCEPTS

• Human-centered computing → Interaction design.

KEYWORDS

Sensory extension, human augmentation, interactive simulations.

ACM Reference Format:

Chris Hill, Casey Lee Hunt, Sammie Crowder, Brett L. Fiedler, Emily B. Moore, and Ann Eisenberg. 2023. Investigating Sensory Extensions as Input for Interactive Simulations. In *TEI '23: Proceedings of the Seventeenth International Conference on Tangible, Embedded, and Embodied Interaction (TEI '23)*, February 26-March 1, 2023, Warsaw, Poland. ACM, New York, NY, USA, 7 pages. <https://doi.org/10.1145/3569009.3573108>

*the first two authors equally contributed

Permission to make digital or hard copies of part or all of this work for personal or classroom use is granted without fee provided that copies are not made or distributed for profit or commercial advantage and that copies bear this notice and the full citation on the first page. Copyrights for third-party components of this work must be honored. For all other uses, contact the owner/author(s).

TEI '23, February 26-March 1, 2023, Warsaw, Poland

© 2023 Copyright held by the owner/author(s).

ACM ISBN 978-1-4503-9977-7/23/02.

<https://doi.org/10.1145/3569009.3573108>

1 INTRODUCTION

Sensor technologies enable us to design systems that augment our experience of the world, facilitating perception beyond our innate biological capabilities. *Sensory extensions* – devices that enhance sensory abilities [25] – take in qualities of an object or event outside our sensing capabilities, and relay that information in a perceptible format. For instance, a sensory extension for e-textile makers allows the wearer to “hear” a loss of electrical continuity while sewing conductive traces [18]. In this work, sensory extensions are utilized as multimodal input devices to a graphical user interface, transforming traditional interface into a multisensory experience.

Interactive simulations and sensory extensions both enable the perception of abstract phenomena. Traditionally, interaction with computer simulations is limited to input devices such as the mouse, keyboard, and touchscreen. Using commercial sensors and computer vision techniques, input modalities for simulations have expanded to incorporate tangible manipulatives, camera tracking, and accelerometers [14, 23, 37]. Multiple modes of input increase inclusivity for users with diverse needs, facilitate new types of interaction, and create more immersive experiences [7–9, 11, 31].

To explore this design space, we created a suite of sensory extension devices for use with an interactive simulation, the PhET simulation *Ratio and Proportion*. The devices provide users with a quantified sense of force, distance, sound frequency, and magnetic field strength, allowing them to vary the intensity of these stimuli as input to the simulation. We then conducted workshops to explore the role of these multimodal sensory extensions in computer simulation interaction. In this paper, we describe the insights observed in these workshops; the sensory extension devices used for this elicitation; and design considerations for integrating sensory extension devices with interactive simulations that emerged from feedback provided by workshop participants.

2 RELATED WORK

2.1 Sensory Extension

Sensory extension devices enhance human perceptual abilities. The devices we present in this paper are a suite of wearable sensory extensions that enhance the user’s ability to detect and measure finite changes in four different stimuli. These systems either enable a user to perceive phenomena humans cannot ordinarily detect or provide enhanced resolution to current senses. For a system to enhance a sense, it should heighten a users’ sensory capabilities and integrate with the body (e.g., wearable) [20]. Sensory extension devices can be standalone, or paired with other technologies such as desktop computers [30], mobile phones and tablets [22], wearable devices [10, 28], and AR/VR headsets [17, 24].

Within Human-Computer Interaction, researchers have designed sensory extensions that offload information onto underused sensory channels [12], augment the abilities of people with diverse needs, including users with disabilities [10, 16], facilitate learning [15, 21], and expand awareness of environmental and personal phenomena [32]. A classic example of a sensory extension device is a belt developed by Nael et al. that detects Earth’s magnetic field [28]. This belt provides the wearer with orientation information obtained via an embedded magnetic compass and gives directional information through vibration. By detecting Earth’s magnetic field

and transducing this quality into haptic output, this device allows users to “learn” an additional sense and to integrate this capability into their perceptual experience of the world.

2.2 Sensory Extension for Interactive Experiences

Sensory extensions can expand interaction modalities for simulations. Previously, sensory extensions have been explored as a way to engage users’ bodies to facilitate experiential learning. These designs include a wearable system that replicates the activity of a polar bear in a melting Arctic environment, mimicking the exertion of the bears as participants “swim” with weighted paws [27]; a worn e-textile that gives children an extended sense of bodily processes through biometric feedback [29]; and a bee puppet device that introduces children to system-wide thinking as they work in teams to collect nectar from electronic flowers [40].

In the Ambient Wood project, researchers provided participants with novel ways to interact with a forest, including a probe that measures the moisture level of soil. This probe enabled participants to quantitatively compare the water content of soil in different parts of the forest environment [33]. During this early example of sensory extension in education, researchers reported that their designs increased participant engagement, but occasionally distracted participants from learning goals. Our research investigates the use of an inclusive multimodal simulation as output for a suite of sensory extension devices. Similar in spirit to the Ambient Wood project, we report on the interaction patterns of participants that used our novel system to provide insights for future sensory extension controlled simulations for educational settings.

2.3 Multimodal Interactive Simulations

The PhET Interactive Simulations project creates inclusively-designed simulations that are multimodal. These designs utilize auditory displays (sonification, sound effects, and verbalized text description [13, 35, 41]); and tangible elements (haptics, touch-based interaction, and manipulatives [38]) to make simulations more engaging and accessible. Previous works have demonstrated that embodied interaction with math simulations change the way users learn ratios [14] and arithmetic [34]. Building upon this avenue of research, collaboration between the Embodied Design Research Laboratory at the University of California Berkeley and the PhET Interactive Simulations project resulted in the *Ratio and Proportion* simulation. This simulation is designed to enable embodied learning by allowing users to create ratios by varying the position of their hands. Relative hand position is detected by a computer vision algorithm applied to a live webcam stream from the learners’ device. Users see these ratios represented on-screen and hear them through sound effects and verbal descriptions. In this work, we explore another approach to multimodality in the *Ratio and Proportion* simulation, providing participants with sensory extensions to create ratios.

3 RATIO AND PROPORTION SIMULATION

In *Ratio and Proportion* [3], learners raise and lower a left and right hand (Fig. 2) to explore the ratio of hand heights. For example, a user might be asked to create a 1:2 ratio, where the right hand must be twice as high as the left hand. When the hands are at



Figure 2: The visual display for the PhET Simulation, *Ratio and Proportion*, with hand positions far from (left), close to (middle) and at (right) the target ratio (1:2). The background changes from white (left) to dark green with increasing saturation (middle and right) as the target ratio is approached.

heights corresponding to the selected challenge ratio, the simulation provides visual and auditory feedback (background turns green, a confirmatory chime plays, and if enabled, speech description voices “hands at challenge ratio”). When hands approach the challenge ratio, visual and auditory feedback support learners’ awareness of this proximity (background becomes more green, the tempo of a plucking sound increases, and if enabled, speech description voices “hands very close to challenge ratio” and “hands extremely close to challenge ratio”).

Once learners are comfortable identifying multiple values that satisfy the challenge ratio, they can explore moving the hands while maintaining the challenge ratio continuously. Learners often initially fix the distance between the hands as they move them upward, and find this is not the solution. Upon finding a successful solution, the learner might conclude, “The higher the hands go, the bigger the distance [between the hands] needs to be” [36]. When users explore ratios with their own bodies, they learn to move in a new way (proportionally), while building embodied representations for the mathematical concept (the spatial interval between their own hands). The design of novel input devices for interactive simulations provides an opportunity to expand embodied interaction beyond the webcam/sensorimotor association, facilitating users’ creation of new sensory associations with mathematical ratios.

4 SENSORY EXTENSION DEVICE DESIGN

For this exploration of sensory extensions as input to interactive simulations, we designed devices that allow users to perceive the ratio between weights, sound frequencies, distances, and/or magnetic fields as input for the *Ratio and Proportion* simulation. These devices enhance users’ senses by giving them a quantified output of the ratio between phenomena that are not ordinarily perceived as numerical values or are not naturally comparable. For example, users do not typically have a natural sense of the ratio between a sound frequency and a distance. With our design, the ratio between these phenomenon is displayed in the *Ratio and Proportion* simulation.

Each sensory extension device consists of a sensor, a device control unit, and an armband. Each sensor is placed in a corresponding 3D printed wearable housing and connected to the control unit.

The central control unit (Fig. 3) houses a rechargeable battery and a Bluetooth microcontroller that sends data to the *Ratio and Proportion* simulation. Each housing uses color, icons, and labels to indicate the sensor type and hand association (left or right) that the unit uses to interact with the simulation.

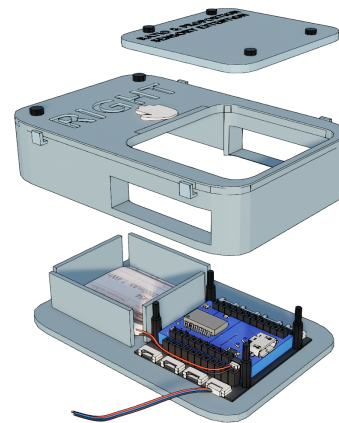

Figure 3: Exploded view of a sensory extension device control unit.

The devices communicate with the simulation with Bluetooth Low Energy protocol and the simulation uses the Web Bluetooth API [42] to receive values from the devices. Each sensory extension device is assigned a device name corresponding to the left or right hand. The simulation filters devices based on the particular hand connected, to ensure that a sensory extension device worn on the left arm will control the left hand in the simulation, and vice versa.

4.1 Weight Sensor Unit

The weight sensory extensions measure force on the wearer’s palm. Users create ratios by holding objects with different weights or by applying force to their palms (i.e. by clenching their fists or pressing their hands against a surface). As the measured force

increases, the corresponding hand in the simulation moves higher. We measure the weight applied using a force-sensitive resistor (FSR) [6] combined with housing that distributes the force across the sensor (Fig. 4a). We mapped the FSRs values to measure weight from 100 grams to 9000 grams. The housing for the weight sensory extension contains five parts: a bottom plate, a button, the button platform, a top plate [39], and an elastic band. The FSR is glued to the bottom plate, and the elastic band is threaded through the top and bottom plates to create the housing. The button is placed inside the top plate and then the platform is fit pressed into the button. The platform makes contact with the FSR when a force is applied to the sensor. Participants were provided with a weight set while using this extension.

4.2 Magnetic Field Sensor Unit

The magnetic field sensory extensions enable the user to measure magnetic field strength. Users create ratios by varying the proximity to and strength of a magnetic field source. The devices use two giant magnetoresistance (GMR) analog sensors [1] to measure magnetic field strength (Fig. 4b). The GMR sensors are omnipolar, meaning the sensor output is always positive regardless of magnetic field polarity. As the strength of the magnetic field increases, the corresponding hand in the simulation moves higher. The housing for the GMR sensor [43] is a flexible 3D printed TPU sleeve worn on a fingertip. We provided participants magnets of varying strengths to explore with the device. We also encouraged participants to search for magnetic fields in the space around them and to use a combination of the provided magnets and environmental magnetic fields to create ratios in the simulation.

4.3 Distance Sensor Unit

The distance sensory extensions measure the distance between the user's hands and a surface. Users reach target ratios by moving their hands closer and farther away from a surface. Each device uses a time of flight sensor [19] fitted into a 3D printed ring (Fig. 4c) to detect the distance between the sensor and a surface. When using this sensory extension, the user wears the ring on a finger with the sensor facing away from their palm. As the distance between their hand and a surface increases, the corresponding hand in the simulation moves higher. The sensors are mapped to measure distances between 1 mm to 600 mm.

4.4 Frequency Sensor Unit

The frequency sensory extensions measure the frequency of sound waves. The devices measure audio frequencies from 10kHz to 21kHz. For perspective, infants can hear up to 20kHz, and the average adult can hear up to the 16-17kHz range. The microphones are glued into 3D printed ears [2] and backed with velcro (Fig. 4d). The ear can be held in the hand or attached to a corresponding armband. The devices use an analog MEMS microphone [4] and a 2-stage Op Amp that amplifies the audio signal from the mic. The microphone and Op Amp can measure sound frequencies from 60Hz to 21kHz, but we limit the detected sound frequency to the high frequency 10kHz to 21kHz range to reduce environmental interference. We provided participants with a digital tone generator to create frequencies within the 1Hz to 21kHz range. They hold the microphone near

the tone generator or explore sounds in the environment to create ratios in the simulation. The higher the frequency detected by the device, the higher the corresponding hand moves in the simulation.

5 WORKSHOPS WITH HIGH SCHOOL YOUTH

5.1 Workshop Design

We collected feedback from high-school-aged youth across two author-facilitated workshops held in conjunction with a university-affiliated STEM summer camp. The first 9-hour workshop was conducted across three, three-hour sessions with 19 participants in a 2-week engineering-focused program. These participants were recruited both locally and nationally. The second 6-hour workshop was held over two, three-hour sessions with 11 regionally-recruited interns in a month-long program on the use of Maker technologies to create accessible media. In both workshops we engaged participants in activities and discussions using the sensory extension devices, and co-design of new sensory extensions. This paper focuses on one activity during the workshops, where participants provided feedback using sticky notes as they used the sensory extension devices designed by our team with the *Ratio and Proportion* simulation. The research team then used affinity diagramming [26] to sort the notes into themes and design considerations. Of those participating, 23 youth (13 and 10, respectively) consented with parental permission to have their video and audio data analyzed and shared for research purposes. All participants are referred to using aliases in the proceeding data analysis.

5.2 Themes and Design Considerations

5.2.1 Playful Interaction and Collaboration.

Participants gravitated toward utilizing the *Ratio and Proportion* simulation in pairs, with each person wearing a single sensory extension device. As a result, participants tended to collaboratively probe for solutions in the simulation. For one pair of participants, Sara and Juliana, this shared control enabled them to work together to make sense of the simulation. At the start of their interaction with the simulation using the distance sensor, Sara says, "I don't get this," to which Juliana replies, "I think we are supposed to make ratios." After finding the first correct configuration, and receiving confirmation with auditory and visual feedback, they began looking for more ratios. Soon Sara was calling out position values of the hand she controlled as she varied the distance between her hand and the table, giving Juliana the ability to find the second value in the ratio. Collaborative interactions with the devices also created a game-like experience to some. In one interaction, Ken wore the weight sensory extension and Aliyah wore the distance sensory extension. While the two collaborated to achieve different ratio goals in the simulation, they noted that the experience of creating ratios together felt playful: Ken said, "having someone else do a different one it's like a multiplayer game".

5.2.2 Device Form Factor.

Participants provided a significant amount of feedback regarding the form factor of the devices. One participant noted that they liked how the control units were "customizable for hand/wrist size and left and right are clearly labeled." Another said, "I like how they look." Other comments included requests for several sizes of



Figure 4: (a) Weight, (b) Magnetic Field, (c) Distance, and (d) Frequency sensor units.

distance sensing rings (we provided a single size), and uncertainty about the way to wear the magnetic field sensor and the distance sensor ring. Participants reported confusion when the device form factor did not align with their interaction expectations. For example, one participant tried using the weight sensor on a table, rather than on their palm, and indicated that the elastic band made it difficult to use in this context.

With this feedback, we conclude that sensory extensions should be flexible in the way they attach to the body, and that designers should provide additional options to use sensors in non-wearable configurations. For example, adding a removable strap to the weight sensory extension would allow participants to use it in the hand as well as on a tabletop. In the case of the distance-sensing rings, multiple sizes or alternative form factors – such as the head-mounted distance sensor suggested by a participant – would give users a greater degree of wearable flexibility.

5.2.3 Sensor Mapping/Sensitivity.

Several participants provided comments about the relationship between the sensor input and the simulation model. Some liked the mapping: “I enjoyed how effective the hand motion sensor was” and “the magnetic field is good with detection.” Others suggested changing the mapping of the sensor to improve the use of the sensory extensions with the simulation. Some noted that they were unable to attain the maximum value with the weight sensory extension devices and that they would prefer a more sensitive device. Another participant indicated the opposite: they disliked that it was possible to “max [the weight sensor] with one finger”. One participant requested that the weight sensory extensions represent the actual weight measured, i.e, moving the hands on the simulation halfway up the range would indicate that a weight of 500 grams was applied to the sensor.

In another example, at least one participant found the direction of the mapping of the magnetic field sensory extension counter-intuitive. Our default mapping increased the value of the hands as the input value increased. In other words, as a participant's hand was lowered to approach a magnet resting on a tabletop, the corresponding hand in the simulation would increase in value. One participant indicated a desire to reverse the mapping: “the magnets should be on top, and that definitely, like, messes with me. Just when I’m moving my finger it’s moving away from the magnetic field... that doesn’t translate very well.” Participant feedback regarding the mapping and smoothing of the sensors was sometimes conflicting.

For example, two participants indicated that the mapping of the hearing extension was too sensitive, while another stated that the hearing extension should be more sensitive. We view the conflicting feedback as indication that designers could improve the experience of using the sensory extensions by providing customization options for sensor mapping, to accommodate differences in sensory needs and preferences.

5.2.4 Combining Multimodal Inputs and Multimodal Outputs.

Participants shared several comments about the relationship between sensor input and the multimodal simulation outputs. One noted that they liked the auditory display, as an “interesting sound visualization”. Additionally, other participants shared that they enjoyed seeing their interactions with intangible phenomena (such as magnetic fields) reflected in the on-screen feedback of the simulation. However, in some cases the simulation feedback did not connect with the participants’ physical experience, and created ambiguity because they could not tell when they hit the target ratio. As one note read: “I wasn’t really sure if I got the right proportion because there were just different shades of green (not sure which green was right)”. As a solution to this ambiguity, participants suggested alternative sonification options (such as changing tone in addition to existing tone speed changes). In addition, participants requested haptic outputs to be integrated into the sensory extension devices that vibrate when close to the target ratio.

While the auditory display (speech description and sonification) was active during the workshop sessions, the number of simulations simultaneously in use coupled with the noise in the room made it difficult to hear and interpret the speech description and auditory cues. One participant noted, “there’s not really a way to do it without seeing - at least not from how we were [using the extensions].” This highlights the need to evaluate interactive simulations in a variety of environmental conditions. Additionally, the feedback we received about the ambiguity of auditory and visual “success” cues when using the sensory extensions suggests the importance of designing simulation outputs with the type of input modality in mind. For example, while traditional keyboard and mouse navigation of the simulation allows users to keep a hand in a stationary position and change values in the simulation stepwise, our sensory extensions require hands to be held steady to meet the criteria for a successful ratio. As a result, it is more difficult to achieve and maintain the success condition of the simulation with the sensory

extension devices. These differences in input affordances changed the effectiveness of simulation feedback.

5.2.5 Sensory Extension Devices and Simulations as a Flexible Tool.

During the workshops, participants made connections to real-life scenarios while using sensory extensions to create ratios. Specifically, they shared ideas about situations where extending one's sense of ratios between weights, distances, sounds, and magnetic field strengths could be useful to complete different types of tasks. One group using the weight sensory extension devices imagined that a chef might leverage the ability to quantify the ratio of hand-held weights to measure ingredient ratios on the fly: "if a chef was holding ingredients in his hands he could see if they are one to three." Another participant suggested using the weight device for physical therapy, allowing a patient to measure their strength in hand calisthenics routines. For the magnetic field sensory extension device, a participant envisioned an electrician using the device to determine if electrical components are working properly by comparing their magnetic fields.

After using the sensory extension devices as input, participants began to think about the devices and simulation as flexible tools that could be applied to different scenarios. Discussing the sensory extension devices in real-world scenarios came naturally to participants, pointing to the opportunity to ground simulations in participants' lived experiences. The *Ratio and Proportion* simulation scaffolds user discovery of an abstract target ratio (1:2, 1:3, etc) that lends itself to completing a task that utilizes exact ratios of weights, magnetic field strengths, sound frequencies, or distances. By embracing this opportunity to utilize the sensory extension devices to ground the concept of the simulation in real-life, we can enrich users' understanding of ratio and proportion.

6 CONCLUSION AND FUTURE WORK

In this paper, we explore the role of sensory extensions in computer simulation interaction. Through combining multimodal inputs with *Ratio and Proportion* and analyzing feedback provided by high-school-aged youth about their experiences during open-ended exploration with these designs, we contribute themes and considerations that designers should bear in mind when expanding multimodal interaction for use with educational tools. We find our study opens up questions regarding the influence of embodied input –via sensory extension with weight, sound frequency, magnetic field, and distance –upon students' mathematical understanding of ratio and proportion. We are also interested in the impact of learners' use of the sensory extensions in different application scenarios (e.g. cooking) while using a mathematical tool, such as *Ratio and Proportion*, and the ways that the combination of sensory extension and interactive simulations may change learners' experiences when used to complete a physical task. We plan to apply what we have learned from our workshops with the *Ratio and Proportion* sensory extension devices to more direct co-design scenarios with youth. Through this work, we hope to converge on design principles for creating sensory extensions and tools for co-design to use with and for designing interactive STEM simulations, which we anticipate will garner insight into facilitating more inclusive learning experiences.

ACKNOWLEDGMENTS

This material is based upon work supported by the National Science Foundation under Grant IIS-2119303. We would also like to thank the co-design session participants for their contributions, and the University of Colorado Boulder's CU Science Discovery and Build a Better Book programs for their partnership.

REFERENCES

- [1] [n. d.]. AAH002-02E: 0.6 mt sat. Analog sensor, 2 Kohm, RoHS SOIC, 150c. https://www.nve.com/webstore/catalog/product_info.php?cPath=27_28&products_id=509
- [2] [n. d.]. Ear V1 3D model. <https://free3d.com/3d-model/ear-v1--113169.html>
- [3] [n. d.]. Ratio and proportion. <https://phet.colorado.edu/en/simulations/ratio-and-proportion/>
- [4] [n. d.]. Sparkfun analog MEMS microphone breakout - ICS-40180. <https://www.sparkfun.com/products/18011>
- [5] [n. d.]. SparkFun USB to serial breakout - FT232RL. <https://www.sparkfun.com/products/12731>
- [6] 2011. GP. https://www.amazon.com/gp/product/B08BL4PBSZ/ref=ppx_yo_dt_b_search_asin_title?ie=UTF8&psc=1
- [7] Sriram Karthik Badam, Arjun Srinivasan, and Niklas Elmqvist. 2017. Affordances of Input Modalities for Visual Data Exploration in Immersive Environments.
- [8] Rafael Ballagas, Meredith Ringel, Maureen Stone, and Jan Borchers. 2003. IStuff: A Physical User Interface Toolkit for Ubiquitous Computing Environments. In *Proceedings of the SIGCHI Conference on Human Factors in Computing Systems (CHI '03)*. Association for Computing Machinery, New York, NY, USA, 537–544. <https://doi.org/10.1145/642611.642705>
- [9] Diana Carvalho, Maximino Bessa, Luís Magalhães, and Eurico Carrapatoso. 2016. Age Group Differences in Performance Using Diverse Input Modalities: Insertion Task Evaluation. In *Proceedings of the XVII International Conference on Human Computer Interaction (Interacción '16)*. Association for Computing Machinery, New York, NY, USA, Article 12, 8 pages. <https://doi.org/10.1145/2998626.2998664>
- [10] Alvaro Cassinelli, Carson Reynolds, and Masatoshi Ishikawa. 2006. Augmenting spatial awareness with Haptic Radar. In *2006 10th IEEE International Symposium on Wearable Computers*. 61–64. <https://doi.org/10.1109/ISWC.2006.286344>
- [11] Julia Chatain, Marie Demangeat, Anke M. Brock, Didier Laval, and Martin Hachet. 2015. Exploring Input Modalities for Interacting with Augmented Paper Maps. In *Proceedings of the 27th Conference on Interaction Homme-Machine (IHM '15)*. Association for Computing Machinery, New York, NY, USA, Article 22, 6 pages. <https://doi.org/10.1145/2820619.2825002>
- [12] Alois Ferscha, Bernadette Emsenhuber, Andreas Rieni, Clemens Holzmann, Manfred Hechinger, Dominik Hochreiter, Marquart Franz, Andreas Zeidler, and Marcos dos Santos Rocha. 2008. Vibro-Tactile Space-Awareness.
- [13] Brett L. Fiedler, Taliesin L. Smith, Jesse Greenberg, and Emily B. Moore. 2022. For One or for All? Survey of Educator Perceptions of Web Speech-Based Auditory Description in Science Interactives. In *Proceedings of the 19th International Web for All Conference (W4A '22)*. Association for Computing Machinery, New York, NY, USA, Article 5, 11 pages. <https://doi.org/10.1145/3493612.3520456>
- [14] Virginia Flood, Anna Shvarts, and Dor Abrahamson. 2020. Teaching with embodied learning technologies for mathematics: responsive teaching for embodied learning. *ZDM* 52 (07 2020). <https://doi.org/10.1007/s11858-020-01165-7>
- [15] Heng Gu, Kai Kunze, Masashi Takatani, and Kouta Minamizawa. 2015. Towards Performance Feedback through Tactile Displays to Improve Learning Archery. In *Adjunct Proceedings of the 2015 ACM International Joint Conference on Pervasive and Ubiquitous Computing and Proceedings of the 2015 ACM International Symposium on Wearable Computers (UbiComp/ISWC'15 Adjunct)*. Association for Computing Machinery, New York, NY, USA, 141–144. <https://doi.org/10.1145/2800835.2800893>
- [16] Yoni Halperin, Galit Buchs, Shachar Maidenbaum, Maya Amenou, and Amir Amedi. 2016. Social Sensing: A Wi-Fi Based Social Sense for Perceiving the Surrounding People. In *Proceedings of the 7th Augmented Human International Conference 2016 (AH '16)*. Association for Computing Machinery, New York, NY, USA, Article 42, 2 pages. <https://doi.org/10.1145/2875194.2875228>
- [17] Abraham M. Hashemian, Matin Lotfali, Ashu Adhikari, Ernst Kruijff, and Bernhard E. Riecke. 2022. HeadJoystick: Improving Flying in VR Using a Novel Leaning-Based Interface. *IEEE Transactions on Visualization and Computer Graphics* 28, 4 (2022), 1792–1809. <https://doi.org/10.1109/TVCG.2020.3025084>
- [18] Chris Hill, Michael Schneider, Mark Gross, Ann Eisenberg, Arielle Blum, and Mark Gross. 2020. A Wearable Meter That Actively Monitors the Continuity of E-Textile Circuits as They Are Sewn. <https://doi.org/10.1145/3386201.3386217>
- [19] Adafruit Industries. [n. d.]. Adafruit VL53L4CD time of flight distance sensor - 1 to 1300mm. <https://www.adafruit.com/product/5396>
- [20] Karim Jebari. 2015. Sensory Enhancement. (01 2015), 827–838. https://doi.org/10.1007/978-94-007-4707-4_106

- [21] Annie Kelly, Christine Chang, Christian Hill, Mary West, Mary Yoder, Joseph Polman, Shaun Kane, Michael Eisenberg, and R. Benjamin Shapiro. [n. d.]. "Our Dog Probably Thinks Christmas is Really Boring": Re-mediating Science Education for Feminist-Inspired Inquiry. *Proceedings of International Conference of the Learning Sciences (ICLS) 2020* ([n. d.]). <https://doi.org/10.22318/icls2020.935>
- [22] David Lakatos, Matthew Blackshaw, Alex Olwal, Zachary Barryte, Ken Perlin, and Hiroshi Ishii. 2014. T(Ether): Spatially-Aware Handhelds, Gestures and Proprioception for Multi-User 3D Modeling and Animation. In *Proceedings of the 2nd ACM Symposium on Spatial User Interaction (SUI '14)*. Association for Computing Machinery, New York, NY, USA, 90–93. <https://doi.org/10.1145/2659766.2659785>
- [23] Scott Lambert, Brett Fiedler, Chloe Hershenow, Dor Abrahamson, Jenna Gorlewicz, and Aaron Cobian. 2022. A Tangible Manipulative for Inclusive Quadrilateral Learning. (03 2022), 16.
- [24] Joseph J. LaViola, Daniel Acevedo Feliz, Daniel F. Keefe, and Robert C. Zeleznik. 2001. Hands-Free Multi-Scale Navigation in Virtual Environments. In *Proceedings of the 2001 Symposium on Interactive 3D Graphics (I3D '01)*. Association for Computing Machinery, New York, NY, USA, 9–15. <https://doi.org/10.1145/364338.364339>
- [25] Louis Longin and Ophelia Deroy. 2022. Augmenting perception: How artificial intelligence transforms sensory substitution. *Consciousness and Cognition* 99 (2022), 103280. <https://doi.org/10.1016/j.concog.2022.103280>
- [26] Andrés Lucero. 2015. Using Affinity Diagrams to Evaluate Interactive Prototypes. Vol. 9297. 231–248. https://doi.org/10.1007/978-3-319-22668-2_19
- [27] Leilah Lyons, Brian Slattery, Priscilla Jimenez, Brenda Lopez, and Tom Moher. 2012. Don't Forget about the Sweat: Effortful Embodied Interaction in Support of Learning. In *Proceedings of the Sixth International Conference on Tangible, Embedded and Embodied Interaction (TEI '12)*. Association for Computing Machinery, New York, NY, USA, 77–84. <https://doi.org/10.1145/2148131.2148149>
- [28] Saskia K. Nagel, Christine Carl, Tobias Kringe, Robert Martin, and Peter König. 2005. Beyond sensory substitution—learning the sixth sense. *Journal of Neural Engineering* 2 (2005), R13 – R26.
- [29] Leyla Norooz, Matthew Louis Mauriello, Anita Jorgensen, Brenna McNally, and Jon E. Froehlich. 2015. BodyVis: A New Approach to Body Learning Through Wearable Sensing and Visualization. In *Proceedings of the 33rd Annual ACM Conference on Human Factors in Computing Systems (CHI '15)*. Association for Computing Machinery, New York, NY, USA, 1025–1034. <https://doi.org/10.1145/2702123.2702299>
- [30] Noriyasu Obushi, Sohei Wakisaka, Shunichi Kasahara, Katie Seaborn, Atsushi Hiyama, and Masahiko Inami. 2019. MagniFinger: Fingertip Probe Microscope with Direct Micro Movements. In *Proceedings of the 10th Augmented Human International Conference 2019 (AH2019)*. Association for Computing Machinery, New York, NY, USA, Article 32, 7 pages. <https://doi.org/10.1145/3311823.3311859>
- [31] Katherine Perkins and Emily Moore. 2017. Increasing the accessibility of PhET Simulations for students with disabilities: Progress, challenges, and potential. In *Physics Education Research Conference 2017 (PER Conference)*. Cincinnati, OH, 296–299.
- [32] Rosalind W. Picard and Jennifer Healey. 1997. Affective wearables. *Personal Technologies* 1 (1997), 231–240.
- [33] Yvonne Rogers, Sara Price, Geraldine Fitzpatrick, Rowanne Fleck, Eric Harris, Hilary Smith, Cliff Randell, Henk Muller, Claire O'Malley, Danæ Stanton, Mark Thompson, and Mark Weal. 2004. Ambient Wood: Designing New Forms of Digital Augmentation for Learning Outdoors. (01 2004). <https://doi.org/10.1145/1017833.1017834>
- [34] Ayelet Segal. 2011. Do Gestural Interfaces Promote Thinking? Embodied Interaction: Congruent Gestures and Direct Touch Promote Performance in Math. (01 2011).
- [35] Taliesin L. Smith and Emily B. Moore. 2020. *Storytelling to Sensemaking: A Systematic Framework for Designing Auditory Description Display for Interactives*. Association for Computing Machinery, New York, NY, USA, 1–12. <https://doi.org/10.1145/3313831.3376460>
- [36] Sofia Tancredi, Rotem Abdu, Dor Abrahamson, and Ramesh Balasubramaniam. 2021. Modeling nonlinear dynamics of fluency development in an embodied-design mathematics learning environment with Recurrence Quantification Analysis. *International Journal of Child-Computer Interaction* 29 (2021), 100297. <https://doi.org/10.1016/j.ijcci.2021.100297>
- [37] Sofia Tancredi, Julia Wang, Helen Tong Li, Carissa Jiayuan Yao, Genna Macfarlan, and Kimiko Ryokai. 2022. Balance Board Math: "Being the Graph" through the Sense of Balance for Embodied Self-Regulation and Learning. In *Interaction Design and Children (IDC '22)*. Association for Computing Machinery, New York, NY, USA, 137–149. <https://doi.org/10.1145/3501712.3529743>
- [38] J. L. Tennison, J. Greenberg, E. B. Moore, and J. L. & Gorlewicz. [n. d.]. Haptic paradigms for multimodal interactive simulations. *Journal on technology and persons with disabilities* 9 ([n. d.]). <https://par.nsf.gov/biblio/10318226>
- [39] Thingiverse.com. [n. d.]. 50kg loadcell bracket (with fusion 360 design) by IXP. <https://www.thingiverse.com/thing:4856495>
- [40] Naomi Thompson, Kylie Pepler, and Joshua Danish. 2017. *Designing BioSim: Playfully Encouraging Systems Thinking in Young Children*. 149–167. <https://doi.org/10.4018/978-1-5225-1837-2.ch018>
- [41] Brianna J. Tomlinson, Bruce N. Walker, and Emily B. Moore. 2020. Auditory Display in Interactive Science Simulations: Description and Sonification Support Interaction and Enhance Opportunities for Learning. In *Proceedings of the 2020 CHI Conference on Human Factors in Computing Systems (CHI '20)*. Association for Computing Machinery, New York, NY, USA, 1–12. <https://doi.org/10.1145/3313831.3376886>
- [42] WebBluetoothCG. 2022. Web-bluetooth/implementation-status.md at main · webbluetoothcg/web-bluetooth. <https://github.com/WebBluetoothCG/web-bluetooth/blob/main/implementation-status.md#notes>
- [43] ZackFreedman. [n. d.]. Zackfreedman/thunder-finger: Feel electric current... with your finger. <https://github.com/ZackFreedman/THUNDER-FINGER>